

Precision components for
spinning machines

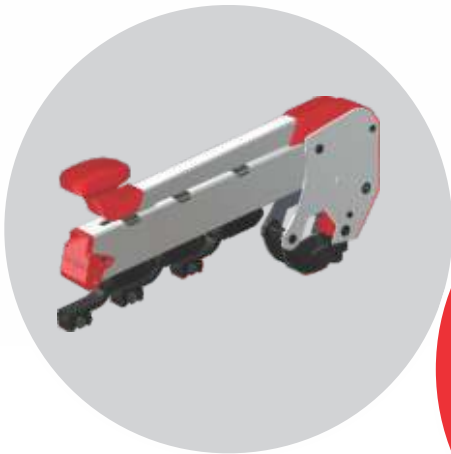

QUALITY
RELIABILITY
INNOVATION





TeraSpin, a business unit of A.T.E. Group, manufactures precision components for spinning machines at its state-of-the-art eco-friendly manufacturing facility at Sari, near Ahmedabad, India. TeraSpin's product range includes **complete drafting systems (weighting arm, top roller and cradle) for roving frames and ring frames and spindles for ring frames**. TeraSpin also provides customised **upgrades for roving frame and ring frame drafting**.

TeraSpin was formed with A.T.E.'s takeover of the textile machinery components business of SKF India in 2012. TeraSpin products are thus built on the strong foundation of SKF knowledge and expertise.

Thereafter, through constant R&D at TeraSpin, these products are continuously improved upon to ensure high performance and durability and many new products are also developed.

With a clear mandate of **'zero defect', 'zero rejection', 'excellence in quality', 'safety' and 'eco-friendly operations'**, TeraSpin has deployed a series of quality initiatives, such as **ISO 9001:2015, ISO 14001:2015 and OHSAS 18001:2007**. Thus, we ensure product quality at every stage of the production process. All products are manufactured with a high degree of automation that helps achieve consistent quality and traceability on a mass scale.

At TeraSpin we manufacture all products as close to their nominal specification limits as possible as shown in the peaked bell curve of the normal distribution – driving towards Six Sigma quality levels.

TeraSpin's products are used by **OEMs** as well as for upgrades and replacement by **spinning mills in 23 countries** across the globe - China, Germany, India, Bangladesh, Indonesia, Japan, Korea, Spain, Turkey, Vietnam, Canada, Mexico, Argentina, Italy, Egypt, Iran, Uzbekistan, Thailand, Taiwan, Nigeria, Kenya, UAE & Nepal.

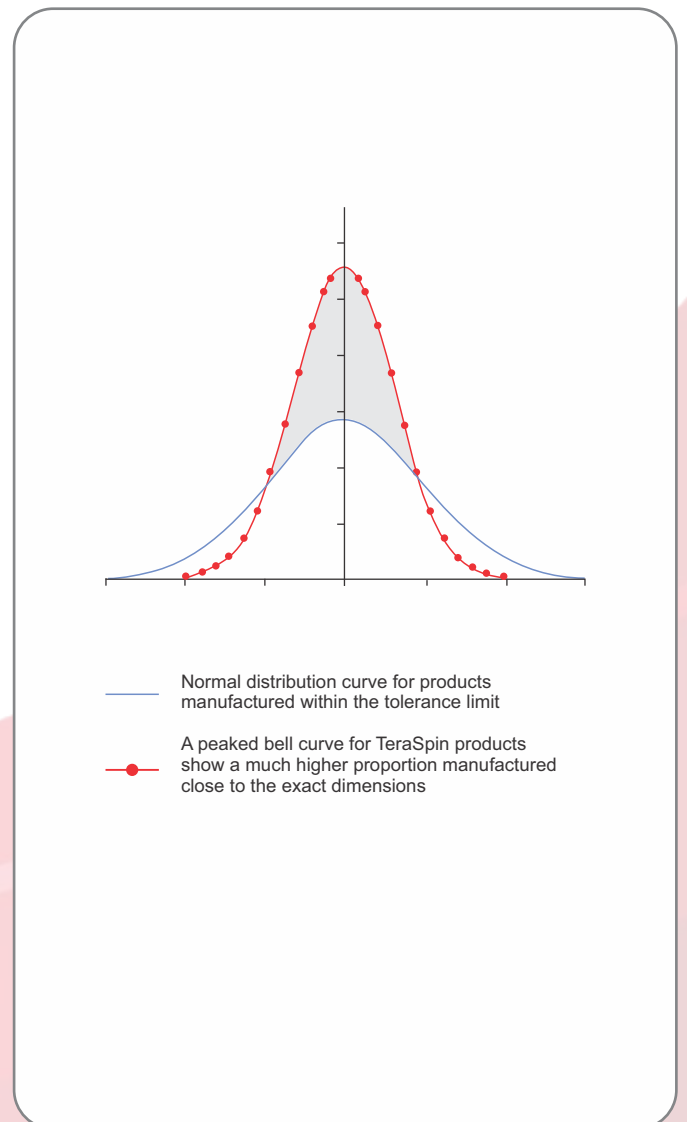

Weighting arms for short staple and worsted ring frames



Features

- Reliable loading through leveraged force of helical coil springs
- Choice of load selection on each top roller
- Partial load release

Benefits

- Consistent quality of yarn
- No height gauge setting required after cot buffing within the specified range of the cot diameters
- No pressure loss or pressure variations
- Suitable for a wide variety of fibres and yarn counts
- Virtually maintenance-free
- Long service life

TeraSpin weighting arms for ring frames are characterised by their **robust design and corrosion resistant finish**. These weighting arms are built to **last the lifetime of the ring frame**. The loading springs used on TeraSpin weighting arms are pre-calibrated for specified loads and also last the product's lifetime. Each **weighting arm exerts the same load on top rollers** irrespective of how long it is in use or at what position in the machine it is fastened.

For short staple ring frames

PK 2025-1251331	For short cradle
PK 2035-1251784	For medium & long cradle
PK 2025-22R	With higher front top roller load suitable for short cradle
PK 2035-22R	With higher front top roller load suitable for medium & long cradle

For worsted ring frames

PK 1601-01 YB	Yellow passivation with black knob
PK 1601-01 SB	Silver passivation with black knob

Weighting arms for roving frames



TeraSpin weighting arms for roving frames are characterised by their **robust design and corrosion resistant finish**. These weighting arms are built to **last the lifetime of the roving frame**. The loading springs used on TeraSpin weighting arms are pre-calibrated for specified loads and also last as long as the roving frames weighting arms. Each **weighting arm exerts the same load on top rollers** irrespective of how long it is in use or at what position in the machine it is fastened.

3-roller drafting – for top roller dia. 28/25/28 and 35/33/35 mm

PK 1500-0962604 YB	Yellow passivation with black knob
PK 1500-0962604 SB	Silver passivation with black knob
PK 1500-0962604 SR	Silver passivation with red knob

3-roller drafting – for top roller dia. 35/25/35 mm

PK 1500-0962602 YB	Yellow passivation with black knob
PK 1500-0962602 SB	Silver passivation with black knob
PK 1500-0962602 SR	Silver passivation with red knob

4-roller drafting – with cradle at 3rd roller position

PK 1500-0001938 YB	Yellow passivation with black knob
PK 1500-0001938 SB	Silver passivation with black knob
PK 1500-0001938 SR	Silver passivation with red knob

4-roller drafting – with cradle at 2nd roller position

PK 1500-0001940 YB	Yellow passivation with black knob
PK 1500-0001940 SB	Silver passivation with black knob
PK 1500-0001940 SR	Silver passivation with red knob
PK 1600-40 YB	Yellow passivation with black knob
PK 1600-40 SB	Silver passivation with black knob

Features

- Reliable loading through leveraged force of helical coil springs
- Available in 3-roller and 4-roller drafting configurations
- Choice of load selection on each top roller
- New ergonomic design of knob

Benefits

- Consistent quality of yarn
- No height gauge setting required after cot buffing within the specified range of the cot diameters
- No pressure loss or pressure variations
- Suitable for a wide variety of fibres and roving hanks
- Virtually maintenance-free
- Long service life

Flexi weighting arms



Air Is Free, But Compressed Air Is Not!

Features

- Fits on the existing hexagonal tube of a pneumatic drafting system
- Accommodates the existing top rollers
- Easy height (pressure) setting
- Adaptable to existing compact yarn systems
- Consistent reliable loading through helical springs
- Options of 5 different loads on each top roller
- Easily replaceable weighting elements
- Adjustable front roller offset

Benefits

- Minimal investment and better payback
- Consistent loads delivering consistent yarn quality
- Ease of installation and retention of existing components
- Ease in maintenance – no pressure checking/ losses due to compressor and change of cot diameters
- Flexibility to handle wide variety of fibres/yarn counts to suit today's fashion industry demand
- Attractive price:performance ratio
- Longer reliable service life
- Contributes to your initiative of sustainable solutions in the textile industry

Spinning mills use pneumatic weighting arms and/or mechanical (spring loaded) weighting arms on their ring frames. **Spring loaded mechanical weighting arms are usually preferred as they are maintenance free and also more reliable** in handling most textile fibers. As **spring loaded weighting arms** do not use compressed air, they **do not consume energy**. Hence, these weighting arms offer a **more sustainable solution** compared to pneumatic weighting arms. The yarn quality is also better and more consistent over a period of time.

Ring frames originally equipped with pneumatic weighting arms may be switched over to mechanical weighting arms that can handle all fibres with ease and better operating performance. With no compressors, hoses, etc., mechanical weighting arms save a sizeable recurring operations and maintenance cost! However, the one time cost of such conversions was a major deterrent for spinning mills to make a decision switch over.

TeraSpin's Flexi weighting arms address these challenges. The PK S 3200 series Flexi weighting arm for short staple ring frames offers maximum flexibility and can be retrofitted onto the existing arrangement of a mill's ring frames with existing drafting components like top rollers and compact systems. This enables the most economical changeover from pneumatic drafting systems to the more reliable and flexible mechanical drafting.

Variants	
PK S 3210	For short cradle, TeraSpin top rollers
PK S 3220	For short cradle, existing top rollers
PK S 3230	For compact (element directly loading compact roller), existing top rollers
PK S 3231	For compact with leaf spring, existing top rollers
PK S 3240	For compact (element directly loading compact roller), TeraSpin top roller
PK S 3241	For compact with leaf spring, TeraSpin top rollers
PK S 3215	For medium/long cradle, TeraSpin top rollers
PK S 3225	For medium/long cradle, existing top rollers

Spindles



TeraSpin is one of the few manufacturers of complete spindles that make **spindles and inserts which enable ring frames to attain speeds up to 25,000 rpm (mechanical)**.

TeraSpin spindles are specially designed for **smooth running at high spindle speeds**. Optimisation of various design parameters, a high level of manufacturing precision, and high-quality German components reduce the vibration and noise level of the spindle.

Spindles are available with different design combinations:

- Aluminium plug type
- For manual doffing ring frames
- For auto-doffing ring frames
 - with TeraSpin Smart Yarn Catchers
 - with knurling and cutters
- Suitable for
 - 4-spindle tape drives
 - tangential belt drives
- Equipped with
 - self-locking inserts or external locking hooks
 - spring type buttons or centrifugal type buttons

HF 100	For spindle speeds of up to 25,000* rpm (mechanical)
HF 1	For spindle speeds of up to 22,000* rpm (mechanical)
HF 21	For spindle speeds of up to 20,000* rpm (mechanical)
HF 21C	For spindle speeds of up to 18,000* rpm (mechanical)

**when used under the right conditions*

Premium ES spindles

Energy is a major cost in spinning that eats away the profits of spinning mills. Hence **energy saving, without compromising productivity and quality, is a top priority for spinning mills**.

TeraSpin Premium ES spindles are the best solution to reduce spinning energy cost. These spindles, which are available with HF1/HF100 spindle bearing units with 18 mm wharve diameter are designed to reduce energy consumption significantly. The well proven, strong, and sturdy design of HF1/HF100 spindle bearing units make the spindles suitable for both manual and auto doffing machines.

Features

- **Wharve diameter: up to 18 mm***
- **High level of manufacturing precision for all spindle components**
- **Only two-point contact (at footstep and neck bearing)**
- **Compact neck bearing manufactured with higher precision**
- **Optimised damping of spindle vibrations with improved design and German components**
- **Well proven conical footstep design manufactured with high precision**
- **Spring support for axial load**

Benefits

- **Low vibrations**
- **Low noise level**
- **Long life**
- **Significantly lower energy consumption***

**in Premium ES spindles only*

Smart Yarn Catcher

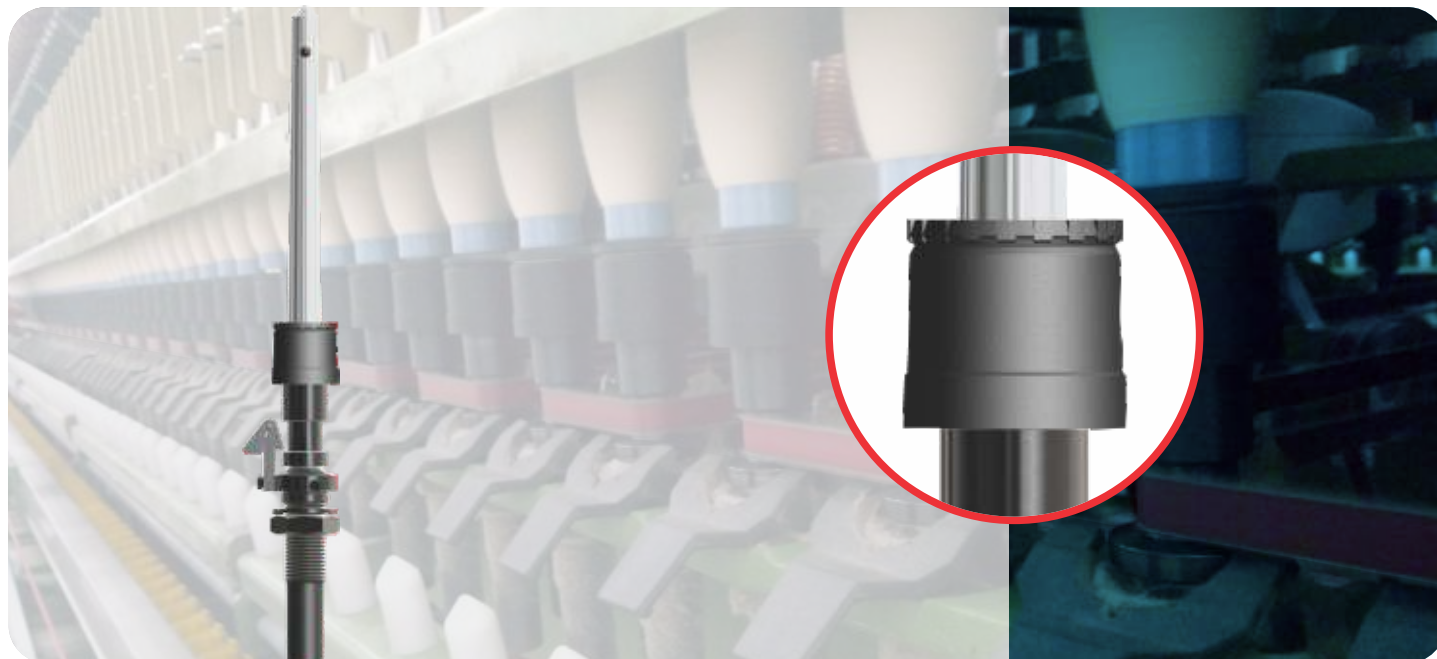

Features

- Automatic opening & closing of clamping faces with change in spindle speed
 - Clamping faces open at about 12500 rpm (+/- 1000 rpm)
 - Clamping faces close at about 6000 rpm (+/- 500 rpm)
- Firm grip of yarn between upper & lower clamping faces which can align precisely with each other due to unique mechanism
- Special cutter for reliable yarn cutting

Benefits

- Minimum yarn used for clamping
- No accumulation of residual yarn – the flat annular clamping faces enable the clamped yarn to move out of device easily by centrifugal forces
- No cleaning of residual yarn – less labour hours
- Reduced start-up breaks
- Improved ring frame productivity
- Very long service life

Accumulation of residual yarn on ring frame spindles at the end of every doff has been a perennial problem for the spinning industry. The accumulated residual yarn is not only a waste of material, but also needs to be manually cleaned, which involves many man-hours and also affects the productivity of the ring frames.

No more accumulation of residual yarn – with the TeraSpin Smart Yarn Catcher (patent pending)

Cradles



Cradles discharge an important function: keeping the apron in position over the rotating apron top roller so that fibres are effectively guided in the main draft zone. TeraSpin cradles are made with metal or Fibre Reinforced Plastic (FRP).

Ring frame cradles

OH 62-1275254	Short polymer cradle, 70 mm gauge
OH 62-1275267	Short polymer cradle, 75 mm gauge
OH 131-1275264	Medium polymer cradle, 70 mm gauge
OH 121-000684	Long metal cradle, 70 mm gauge

Worsted ring frame cradles

OH 554-000075	Metal cradle, 75 mm gauge
---------------	---------------------------

Roving frame cradles

OH 514-1275261	Short polymer cradle
OH 534-1275268	Medium polymer cradle
OH 534-000110	Medium metal cradle
OH 524-000110	Long metal cradle

Features of FRP cradles

- Design ensures gentle nipping and effective fibre control
- Rigid and stable structure for use under mill conditions
- Lighter in weight
- Clean surface for smooth rotation of top aprons
- Can readily replace existing metal cradles

Benefits of FRP cradles

- No chance of deformed cradles being used and hence, no danger of producing poor quality of roving/yarn
- Existing spacers can be used on these cradles
- Consistent roving/yarn quality
- Maintenance-free
- Long life

Smart cradles



Features

- Minimum contact area minimises friction during apron rotation
- Unique design ensures a fixed radius and hence a uniform distance between apron nip and front roller nip
- Accommodates variations in apron length & maintains uniform apron tension

Benefits

- Reduced yarn imperfections
- Longer apron working life
- Easy apron removal and mounting during maintenance

Cradles discharge the important function of keeping the apron in position over the rotating apron top roller so that fibres are effectively guided in the main draft zone. TeraSpin's new range of **Smart cradles** exercise better control over fibres in the front zone and hence give better roving and yarn quality.

Ring frame cradles

OH S 168	Short polymer cradle, 70 mm gauge
OH S 175	Short polymer cradle, 75 mm gauge

Roving frame cradles

OH P 110	Short polymer cradle
OH P 310	Medium polymer cradle

Distance clips



These small, lightweight plastic elements in a drafting system can sometimes make **the difference between good and bad yarn**. TeraSpin ensures that the distance clips you buy are of exactly the same dimensions, thousands after thousands, in every order.

Top rollers



Top rollers are a pair of anti-friction, double row ball bearings having a common axle. **Each top roller is manufactured such that the clearance between the hardened arbour and shell is perfectly matched with appropriately sized double row steel balls.** The top rollers made for ring frames and speed frames are injected with just the right amount of a special grease – TRG 5. The ends are fitted with a uniquely designed seal to prevent leaks while in operation.

Ring frame top rollers

LP 302-000684	LP 302-000075	LP 302-000825
LP S 3681	LP S 3751	LP S 3821
LP 303-000684	LP 303-000075	LP 303-000825
LP 302-000070 L	LP 302-000075 L	LP 302-000070 R
LP 302-000075 R	LP 302-000070 G	LP 302-000080 G
LP 302-000090 G		

Worsted ring frame top rollers

LP 314-000075	LP 314-000825
LP 316-000075	LP 316-000825

Roving frame top rollers

LP 315-000110	LP 317-000110
---------------	---------------

Features

- **Sturdy double row ball bearings with low friction**
- **Through hardened components**
- **Proven and effective U-type sealing**
- **Controlled radial clearances**
- **Lubricated with long life grease – TRG 5**

Benefits

- **Higher load carrying capacity**
- **Smoother rolling of top rollers resulting in better and consistent yarn quality**
- **Smoother rotation leading to longer service life**
- **No ingress of contamination**
- **Reduced maintenance – extended re-lubrication intervals due to TRG 5 grease**

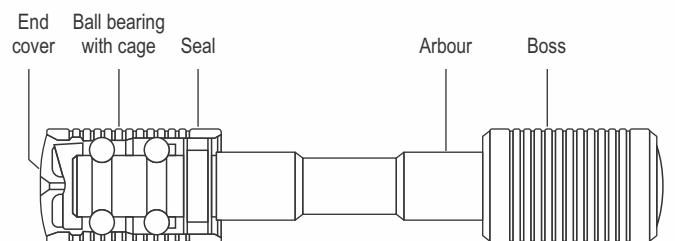

Double row ball bearings with specially designed end seals to prevent grease leakage during use

Upgradation kits



TeraSpin upgradation kits offer the **twin benefits of enhanced performance with low investment** – a viable option adopted by many spinning mills across the globe, since it improves productivity, quality, and energy efficiency.

Drafting zone

Drafting upgradation is the preferred way of improving roving frame and ring frame performance. Outdated mechanical and/or old pneumatic weighting arms can be replaced by the more efficient TeraSpin spring loaded weighting systems. No compressed air is required.

Spindle zone

Ring frames consume almost 60% of the power of the spinning process, out of which spindles and the spindle drive consume approx. 40%. A small saving here will directly reflect in the cost of the yarn. By optimising parameters like spindle wharve diameter, DUI, taper ratio, lift, etc., the power consumption can be considerably reduced.

Benefits

- Increased spindle speed and productivity
- Reduced power consumption
- Improved and consistent quality of output
- Extended machine life
- Improved price/performance ratio

Grease TRG 5

TeraSpin special **grease TRG 5 is specially formulated** to meet the stringent working conditions of the spinning industry. TRG 5 keeps drafting top rollers running with **longer re-lubrication intervals**. Its lubricating properties address the issues of micro dust, fluff, humidity, and temperature in the spinning section. It is also suitable for bottom roller bearings.



Features

- Barium based grease
- High load carrying capacity
- Good metal affinity
- Excellent water resistant properties
- Wide range of working temperature (–30°C to +140°C)

Benefits

- High load bearing capacity
- No ingress of foreign particles
- Long re-lubrication intervals reduce maintenance
- Smooth trouble-free operation under mill conditions
- Consistent quality output

Sustainability at TeraSpin

TeraSpin is not only the epitome of quality, but it also embodies A.T.E. Group's vision of sustainability. Hence, TeraSpin is certified under ISO 14001:2015 Environment Management System for its sustainable practices.

Some of TeraSpin's green initiatives:

- Design of the buildings allows optimum use of natural light. Not a single electrical light is used in the office or factory during the day time
- Green wall structure around the building with various plants and creepers helps to cut down heat coming into the structure
- A water pipe network inside the structure of the building keeps it cooler
- A unique two-stage evaporative cooling technology from HMX (a part of the A.T.E. Group) provides 100% fresh cool air for people comfort and process efficiency
- A sewage treatment plant from A.T.E. HUBER Envirotech (a part of the A.T.E. Group) treats the wastewater and makes it usable for non-potable purposes like watering the trees and plants around the complex
- A special type flooring in the shop floor prevents any seepage into the soil and is easy to clean too
- Hazardous wastes like grinding dust and lubricating oils from the machining centres are minimised, then carefully collected and handed over to government certified agencies for recycling and disposal
- Use of IoT based remote monitoring from EcoAxis (a part of the A.T.E. Group) ensures that the temperatures, CO₂ levels, etc., are always at the intended levels within the manufacturing facility and the office
- Rain water harvesting and reverse bore wells replenish the ground water in the area
- Facility equipped with solar power generation of 85 kW

Manufactured by:



A.T.E. ENTERPRISES PRIVATE LIMITED

(Business Unit: TeraSpin)

Survey no. 251, Sarkhej Bavla Highway (N.H. no. 8A), Village: Sari

Taluka: Sanand, Ahmedabad 382 220, Gujarat, India

T: +91-2717-699061 E: sales@teraspin.com W: www.ategroup.com/teraspin

Marketed and sold by:



A.T.E. ENTERPRISES PRIVATE LIMITED

Bhagwati House, A-19 CTS 689, Veera Desai Road

Andheri (West), Mumbai 400 053, India

T: +91-22-6676 6100 E: poacc@ateindia.com W: www.ategroup.com

Regional Offices

AHMEDABAD

T: +91-79-2560 1694

E: ahdacc@ateindia.com

CHANDIGARH

T: +91-172-269 7179

E: chdacc@ateindia.com

COIMBATORE

T: +91-422-222 3286

E: cbe1acc@ateindia.com

HYDERABAD

T: +91-40-4050 9200

E: hydacc@ateindia.com

KOLKATA

T: +91-33-2357 6501

E: kolacc@ateindia.com

MUMBAI

T: +91-22-6676 6100

E: mumacc@ateindia.com

